

## **Ceylon Motor Yacht Club**

Indibedde, Moratumulla

Moratuwa

Ph: 421 2394

**Monday, April 26, 2010**

# **NOTICE OF RACE**

## **Ceylon Motor Yacht Club CMYC Shackle, 2010**

**Sailed under the burgee of the Ceylon Motor Yacht Club**

**15<sup>th</sup> and 16<sup>th</sup> May 2010**

### **1. ORGANISING AUTHORITY**

- 1.1** The CMYC Shackle are organised by the Ceylon Motor Yacht Club (the Organising Authority).
- 1.2** All enquiries should be addressed to the Event Office, Ceylon Motor Yacht Club, Indibebbe, Mortatumulla, Moratuwa, Sri Lanka.

The Event Office can be contacted by email or phone as follows:

**Phone:** + 94 (11) 421 2394

**Email:** Stephen.giffin@outotec.com or  
jeremy@octagon-consultants.com

### **2. RULES**

- 2.1** The event will be governed by the current ISAF Racing Rules of Sailing (RRS), the prescriptions of the Ceylon Motor Yacht Club (CMYC), the respective Class Rules, the Sailing Instructions (SI's) and this Notice of Race (NOR) and any amendments thereto.
- 2.2** The Organising Authority reserves the right to carry out safety and measurement checks at any time at their discretion.
- 2.3** The Event will be Category C. Competitors shall not display advertising that is believed to be in conflict with the event sponsors.

### 3 THE EVENT

- 3.1 The CMYC Shackle will take place on 15<sup>th</sup> and 16<sup>th</sup> May 2010 at the premises of the Ceylon Motor Yacht Club, Bolgoda.
- 3.2 The Organising Committee reserves the right to refuse any entry and/or to ask entrant to complete further undertakings or declarations before accepting an entry.
- 3.3 The Championship is restricted to the following class: GP14

### 4. RIGHTS TO USE NAME AND LIKENESS

- 4.1 By participating in the Championship a competitor automatically grants to the organizing authority, the Ceylon Motor Yacht Club and the event sponsors, the right in perpetuity, to make, use and show, from time to time and at their discretion any photographs, motion pictures and live, taped or filmed or other reproduction of him/her during the period of the competition without compensation.

### 5. SCHEDULE OF RACES

- 5.1 The Championship shall consist of five (05) races that will take place over the two days, Saturday 30<sup>th</sup> May and Sunday 31<sup>st</sup> May 2009 inclusive. The first gun/bell each day for the respective classes will be as follows:

Saturday 15<sup>th</sup> May:                      No earlier than 1300 hrs.

Sunday 16<sup>th</sup> May:                      No earlier than 1200 hrs.

- 5.2 The provisional schedule will be confirmed on the day by the OOD for the races are as follows:

#### Saturday 15<sup>th</sup> May 2010

<b>First Signal</b>	<b>Event/s</b>
1300 hrs	GP14 Class races 1, 2, and 3 sailed back to back
1700 hrs	Informal get together

#### Sunday 16<sup>th</sup> May 2010

<b>First Signal</b>	<b>Event/s</b>
1200 hrs	GP14 Class races 4, and 5 sailed back to back
1430 hrs	Lunch
1530 hrs	Awards ceremony

**5.3** Registration will take place at the CMYC on Saturday 15<sup>th</sup> May 2010 between 1100Hrs and 1300Hrs.

**5.4** The details of the course(s) to be sailed will be published in the Sailing Instructions, which will be posted on the Notice Board.

**5.5** Subject to change according to weather conditions, a Triangular course will be sailed.

## **6. SCORING**

**6.1** The Low Point System, RRS Appendix A will apply to the Championship. Ties will be broken in accordance with RRS Appendix A8.

**6.2** Four races shall be completed in the Championship to constitute a series.

**6.3** One discard will be allowed if five races are completed in the Championship. In the event of only four or fewer races being completed, no discard will be permitted.

## **7. PRIZES**

**7.1** Prizes will be awarded in accordance with the norms of the Ceylon Motor Yacht Club.

## **8. ENTRY FEES**

**8.1** There will be no entry fee for this series of races.

## **9. SAIL NUMBERS & SPONSORS PENNANT OR DECAL**

**9.1** All boats shall display their correct sail number on the mainsail.

**9.2** All competing boats may be supplied with a sponsor's sticker, which they shall display in accordance with Appendix I – ISAF Advertising Code.

## **10. SOCIAL ARRANGEMENTS & ENTERTAINMENT**

**10.1** Participants are invited informally to get together at the Club Premises from 5 p.m. onwards on Saturday 15<sup>th</sup> May. No beverages brought from outside should be consumed in the club premises, beverages are available for sale from the club bar.

## **11. OWNERS' RESPONSIBILITIES, INSURANCE & WAIVERS**

**11.1** Helms shall be liable for insurance in respect of their own boats, including civil responsibilities to third parties.

**11.3** The Ceylon Motor Yacht Club, members thereof and its sponsors, are providing this Series of Races only on the understanding that the Club, its representatives

and/or members bear no responsibility for any loss, damage, injury or inconvenience to the boats or persons howsoever arising, directly or indirectly, by any accident or wrongful negligent act, default or omission of any member or any other person during the regatta. By registering for the Series of Races, owners acknowledge their responsibility and undertake to draw the attention of their crew to this disclaimer before the start of the event.

## **12. SAILING INSTRUCTIONS**

**12.1** Sailing Instructions will be available at Registration, and will also be circulated in advance to all participants whose e-mail addresses are available with CMYC.

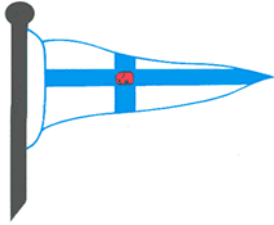

## **Ceylon Motor Yacht Club**

Indibedde, Moratumulla

Moratuwa

Ph: 421 2394

**Monday, 26 April 2010**

# **Sailing Instructions**

## **Ceylon Motor Yacht Club CMYC Shackle, 2009**

**Sailed under the burgee of the Ceylon Motor Yacht Club**

**15<sup>th</sup> and 16<sup>th</sup> May 2010**

### **1. RULES**

- 1.1** The Racing Rules of Sailing 2009-12, the Notice of Race, and these Sailing Instructions will govern the racing of the CMYC Shackle.

### **2 CONDITIONS OF ENTRY**

- 2.1** The CMYC Shackle is open to all Members of the CMYC. Invited guests may only participate as crew for a Member.
- 2.2** The Race Committee may permit a boat to use a sail carrying a number other than the registered boat number. This varies RRS 77
- 2.3** A substitute boat may be permitted at the Race Committee's discretion provided it has a valid Class certificate and authorisation is obtained before going afloat.
- 2.4** Variations granted under 2.1 or 2.2 will be posted on an official notice board as soon as practical.

### **3 SAFETY**

- 3.1** The safety of a boat and her entire management and any insurance shall be the sole and inescapable responsibility of the person designated in charge on the Registration Form. The race organisers shall not be responsible for any loss, damage, death, or personal injury howsoever caused by anybody as a result of taking part in this event.

**3.2** When Int. Code flag Y is displayed with one sound before or with the warning signal, competitors shall wear personal flotation devices, except briefly while changing or adjusting clothing or personal equipment. Wet suits and dry suits are not personal flotation devices

**3.3** A capsized boat, whose mast is stuck in the mud, may receive assistance from the safety boat only to bring her mast up to the surface of the water, without having to retire. This alters RRS 41.

#### **4 NOTICES TO COMPETITORS**

**4.1** Notices will be posted on the board at the Notice Boards.

#### **5 CHANGES TO SAILING INSTRUCTIONS**

**5.1** Changes to these Sailing Instructions may be made at a briefing, or by a Notice posted at least 30 minutes before start of the first race of each day and by hoisting Int. Code Flag L ashore.

#### **6 SCHEDULE OF RACES**

**6.1** The Championship shall consist of five (05) races that will take place over the two days, Saturday 30th May and Sunday 31st May 2009 inclusive. The first gun/bell each day will be as follows:

Saturday 15<sup>th</sup> May: No earlier than 1300 hrs.

Sunday 16<sup>th</sup> May: No earlier than 1200 hrs.

**6.2** A skipper's briefing will be held 45 minutes prior to the start of Race 1

#### **7 STARTING TIMES**

**7.1** Saturday 15<sup>th</sup> May 2010, First Signal, 1300 hrs, Races 1, 2, and 3 sailed back to back

**7.2** Sunday 16<sup>th</sup> May 2010, First Signal, 1200 hrs, Races 4, and 5 sailed back to back

**7.3** Starting times may be postponed or changed at the discretion of the Race Committee.

#### **8 COURSE INSTRUCTIONS**

**8.1** There will be 3 Courses A, B, and C. Refer attached description of courses

**8.2** The Course to be sailed on the day will be displayed on the Notice Board or on the notice board on the Committee Boat.

**8.3** Changes to an advertised course will be prefaced by the hoisting of Int. Code Flag C, accompanied by two sound signals.

## **9 THE START**

**9.1** Races will be started in accordance with RRS 26.

<b><i>Signal</i></b>	<b><i>Flag and sound</i></b>	<b><i>Minutes before starting signal</i></b>
Warning	Class flag; 1 sound	5
Preparatory	P, I, Z, Z with I, or black flag; 1 sound	4
One-minute	Preparatory flag removed; 1 long sound	1
Starting	Class flag removed; 1 sound	0

**9.2** The Start Line will be an imaginary line between the mast flying an Orange flag on the Committee boat and an Outer Limit Mark to port of the Committee Boat.

## **10 RECALLS**

**10.1** Individual Recalls will be signalled in accordance with RRS 29.2 by hoisting Int. Code Flag X, accompanied by one extra sound signal. Such signals will be displayed for a few minutes or until the last boat returns, whichever is sooner.

**10.2** General Recalls will be signalled in accordance with RRS 29.3. In each case, RRS 30.1 (Round the Ends) or 30.3 (Black Flag) may be applied on second or subsequent starts, but sail numbers of premature starters will not be displayed. This amends RRS 30.3. RRS 30.2 (Z flag) will not apply.

## **11 THE FINISH**

**11.1** The Finish Line will be an imaginary line between the mast flying an Blue flag on the Committee Boat and a nearby floating mark to port of the Committee Boat, OR the nearby mark of the course.

## **12 SHORTENED COURSE**

**12.1** A shortened course will be indicated by flying Int. Code Flag S, accompanied by 2 sound signals. This signal will be made from the

Committee Boat as the lead boat rounds the last mark of the course prior to the Finish Line. Boats shall continue to round marks of the course in the required order until the Finish Line is reached.

### **13 PENALTIES**

**13.1** Penalties will be in accordance with RRS 31.2 and 44.2.

### **14 TIME LIMIT**

**14.1** The Time Limit for each race will be 60 minutes. If the first boat finishes within the last 10 minutes of that time, the Time Limit will be extended for 20 minutes after the Finishing Time of the first boat. Boats not finishing within that time will be scored DNF. This amends RRS 35.

### **15 PROTESTS**

**15.1** Protests shall be in accordance with Rule 61.

**15.2** A protest is to be indicated by displaying a red flag from the protesting boat from the time of the incident until they are no longer racing. This alters RRS 61.1(a)(2).

**15.3** A protesting boat should as soon as practical after completion of each race indicate to the Race Officer on the Committee Boat his intention to protest.

**15.4** Protests must be lodged with the Race Officer within 30 minutes of the last boat finishing the day's series of races race.

**15.5** The Protest Committee will be advised by the Race Committee 30 mins prior to the first race of the day.

### **16 SCORING**

**16.1** The Low Point System, RRS Appendix A will apply to the Championship. Ties will be broken in accordance with RRS Appendix A8.

**16.2** Four races shall be completed in the Championship to constitute a series.

**16.3** One discard will be allowed if five races are completed in the Championship. In the event of only four or fewer races being completed, no discard will be permitted.

### **17 PRIZES**

**17.1** Prizes for 1<sup>st</sup> 2<sup>nd</sup> and 3<sup>rd</sup> places will be awarded for CMYC Shackle Overall (BHC only) and CMYC Shackle Handicap (BHC and PHC).

# Course A

Windward – Leeward – Triangle Course

Start – A – B – C – A – C – Finish

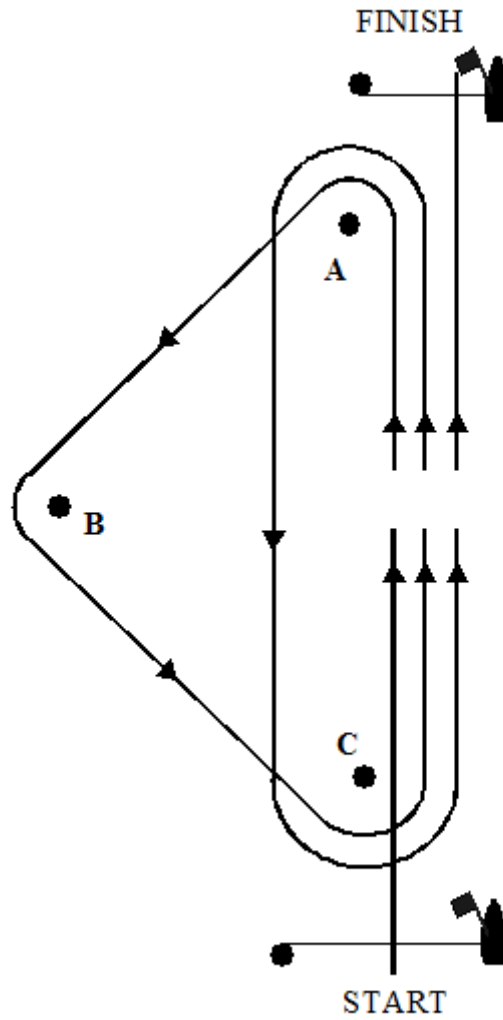

# Course B

Windward – Leeward - Z Course

Start – A – B – D – C - A - C – Finish

All Marks to be Rounded

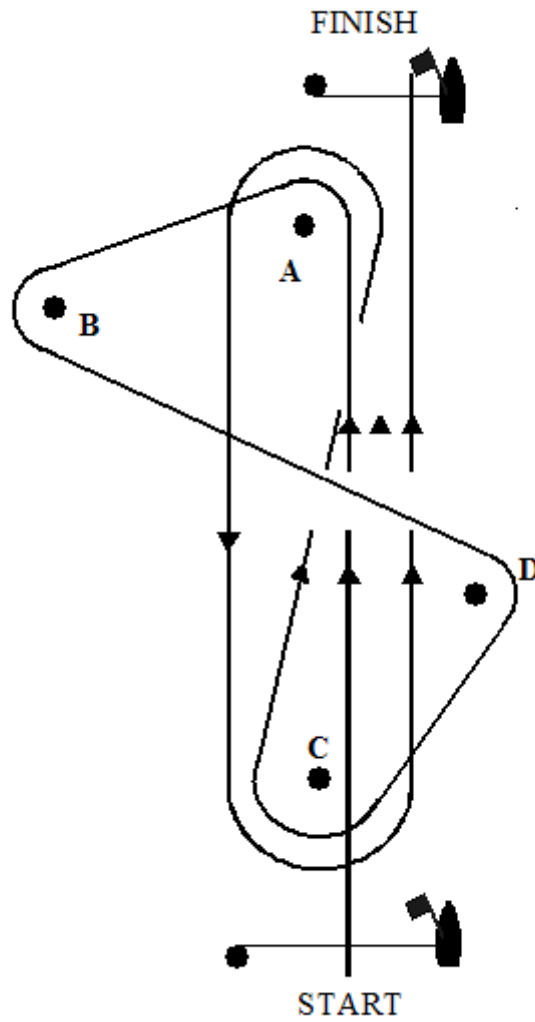

# Course C

Windward – Leeward - Triangle Course

Start – A – B – C – Finish

